



Designation: D4272/D4272M – 15

# Standard Test Method for Total Energy Impact of Plastic Films by Dart Drop<sup>1</sup>

This standard is issued under the fixed designation D4272/D4272M; the number immediately following the designation indicates the year of original adoption or, in the case of revision, the year of last revision. A number in parentheses indicates the year of last reapproval. A superscript epsilon ( $\epsilon$ ) indicates an editorial change since the last revision or reapproval.

## 1. Scope\*

1.1 This test method describes the determination of the total energy impact of plastic films by measuring the kinetic energy lost by a free-falling dart that passes through the film.

1.2 *Units*—The values stated in either SI units or inch-pound units are to be regarded separately as standard. The values stated in each system may not be exact equivalents; therefore, each system shall be used independently of the other. Combining values from the two systems may result in non-conformance with the standard

1.3 *This standard does not purport to address all of the safety concerns, if any, associated with its use. It is the responsibility of the user of this standard to establish appropriate safety and health practices and determine the applicability of regulatory limitations prior to use.*

NOTE 1—Film has been arbitrarily defined as sheeting having nominal thickness not greater than 0.25 mm [0.010 in.].

NOTE 2—This test method and ISO 7765–2 address the same subject matter, but differ in technical content (and results cannot be directly compared between the two test methods). The ISO test method calls for a direct readout of energy by using a load cell as part of the impactor head, while Test Method D4272 calls for a constant weight impactor, then measuring the time of travel through a given distance to get energy values.

## 2. Referenced Documents

### 2.1 ASTM Standards:<sup>2</sup>

- D618 Practice for Conditioning Plastics for Testing
- D883 Terminology Relating to Plastics
- D1709 Test Methods for Impact Resistance of Plastic Film by the Free-Falling Dart Method
- D3420 Test Method for Pendulum Impact Resistance of Plastic Film
- D6988 Guide for Determination of Thickness of Plastic Film Test Specimens

<sup>1</sup> This test method is under the jurisdiction of ASTM Committee D20 on Plastics and is the direct responsibility of Subcommittee D20.19 on Film, Sheeting, and Molded Products.

Current edition approved Oct. 1, 2015. Published October 2015. Originally approved in 1983. Last previous edition approved in 2014 as D4272 - 14. DOI: 10.1520/D4272\_D4272M-15.

<sup>2</sup> For referenced ASTM standards, visit the ASTM website, [www.astm.org](http://www.astm.org), or contact ASTM Customer Service at [service@astm.org](mailto:service@astm.org). For *Annual Book of ASTM Standards* volume information, refer to the standard's Document Summary page on the ASTM website.

E171 Practice for Conditioning and Testing Flexible Barrier Packaging

E691 Practice for Conducting an Interlaboratory Study to Determine the Precision of a Test Method

2.2 ISO Standard:<sup>3</sup>

ISO 7765–2 Plastics Film and Sheeting—Determination of Impact Resistance by the Free Falling Dart Method—Part 2: Instrumented Puncture Test

## 3. Terminology

3.1 *Terminology*—For definitions, see Terminology D883.

3.2 *Definitions of Terms Specific to This Standard:*

3.2.1 *free-fall time*—the measured time required for the dart to travel through the sensing area with no film specimen in the clamp.

3.2.2 *missile mass (SI units)*—the total mass of the dart (kg) including any attached incremental weights and the locking collar.

3.2.3 *missile weight (in.-lb units)*—the total weight of the dart (lb) including any attached incremental weights and the locking collar.

3.2.3.1 *Discussion*—In the energy calculation, the weight is divided by the gravitational constant, “g” to obtain the mass.

3.2.4 *test-fall time*—the measured time for the dart to travel through the sensing area with a film specimen in the clamp.

## 4. Summary of Test Method

4.1 The velocity of a freely falling dart of specified shape that has passed through a sheet of plastic film is determined by means of a photoelectric speed trap. The kinetic energy corresponding to this velocity is calculated and compared with the kinetic energy of the same dart measured without a plastic film in place. The loss in kinetic energy of the dart due to rupturing of the film is used as an index of impact resistance.

## 5. Significance and Use

5.1 Evaluation of the impact toughness of film is important in predicting the performance of a material in applications such as packaging, construction, and other uses. The test simulates

<sup>3</sup> Available from American National Standards Institute (ANSI), 25 W. 43rd St., 4th Floor, New York, NY 10036, <http://www.ansi.org>.

\*A Summary of Changes section appears at the end of this standard

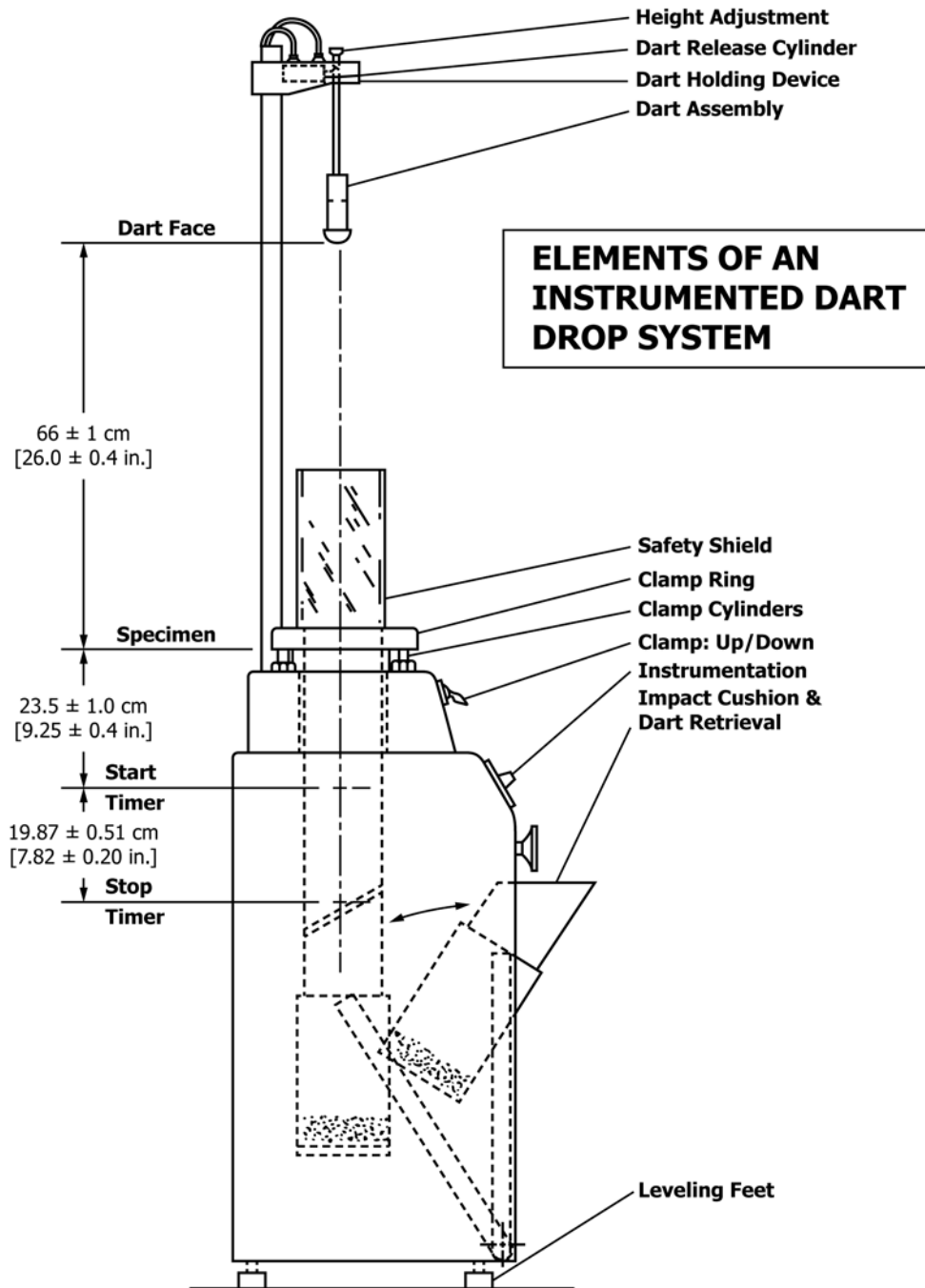

FIG. 1 Elements of an Instrumented Dart Drop System

the action encountered in applications where moderate-velocity blunt impacts occur in relatively small areas of film.

5.2 The values obtained by this test method are highly dependent on the method and conditions of film fabrication as well as the type and grade of resin.

5.3 Test methods employing different missile velocities, impinging surface diameters, or effective specimen diameters will most likely produce different results. Data obtained by this test method cannot necessarily be compared directly with those obtained by other test methods.

5.4 The impact resistance of a film, while partly dependent on thickness, does not have a simple correlation with sample thickness. Hence, impact values expressed in joules [ft·lbf] normalized over a range of thickness will not necessarily be linear with thickness. Data from this test method are comparable only for specimens that vary by no more than  $\pm 15\%$  from the nominal or average thickness of the specimens tested.

5.5 The test results obtained by this test method are greatly influenced by the quality of film under test. The influence of variability of data obtained by this procedure will, therefore,

depend strongly on the sample quality, uniformity of film thickness, the presence of die marks, contaminants, etc.

5.6 Several impact test methods are used for film. It is sometimes desirable to know the relationships among test results derived by different test methods. A study was conducted in which four films made from two resins (polypropylene and linear low-density polyethylene), with two film thicknesses for each resin, were impacted using Test Methods **D1709** (Test Method A), Test Method **D3420** (Procedures A and B), and Test Method **D4272**. The test results are shown in **Appendix X2**. Differences in results between Test Methods **D1709** and **D3420** are expected since Test Methods **D1709** represents failure-initiated energy, while Test Method **D4272** is initiation plus completion energy. Some films may show consistency when the initiation energy is the same as the total energy. This statement and the test data also appear in the significance and appendixes sections of Test Methods **D1709** and **D3420**.

## 6. Apparatus

6.1 The test apparatus shall be constructed essentially as shown in **Fig. 1** and include the following:

6.1.1 A rigid base containing a specimen clamping device, a light sensitive speed trap, and a dart well or chamber for catching and retrieving the dart after impact.

6.1.2 A rigid fixture for holding the dart at the proper height above the film surface. In some equipment designs the dart holding fixture is an integral part of the base unit.

6.1.3 The dimensions of the impact apparatus shall conform to those shown in **Fig. 1** and those listed below.

### 6.2 Specific Requirements for Individual Components:

6.2.1 *Base*—The base shall be rigid enough to prevent movement between the specimen clamp and components of the timing system during impact. It shall be located on a flat surface that provides adequate support to prevent downward movement of the unit during impact. It shall be leveled to insure that the impact surface of the specimen is exactly perpendicular to the trajectory of the dart.

6.2.2 *Specimen Clamp*—The apparatus shall be equipped with a circular clamp to hold the specimen. The clamp shall be mechanically, pneumatically, or hydraulically actuated. The diameter of the clamped area shall be  $127 \pm 2$  mm [ $5.0 \pm 0.1$  in.]. In some equipment designs the clamping surface is equipped with rubber O-rings, round gaskets or other circular devices to prevent slippage of the specimen during impact. The clamp shall hold the specimen so that the impact surface is exactly perpendicular to the trajectory of the dart and at the correct distance from the tip of the dart. During impact, the specimen shall be held with enough force to prevent slippage but not great enough to distort, fracture, or otherwise damage the specimen in such a way as to affect the impact strength of the film.

6.2.3 *Light-Sensitive Speed Trap*—A system comprised of photocells, lasers, or other non-mechanical devices connected to the timing device to measure the time-of-flight of the dart. The distance from the bottom surface of the specimen to the upper (starting) sensor shall be  $23.5 \pm 1.0$  cm [ $9.25 \pm 0.40$

in.]. The length of the speed trap, that is, the distance between the starting and stopping sensors shall be  $19.87 \pm 0.51$  cm [ $7.82 \pm 0.20$  in.].

6.2.4 *Timing Device*—An electronic timer capable of measuring to the nearest  $10^{-5}$  s.

6.2.5 *Dart Well*—The bottom of the dart well shall contain adequate cushioning material to prevent damage to the dart head. If the impact machine utilizes an enclosed dart well, it must contain a single unobstructed vent with a minimum area of  $645$  mm<sup>2</sup> [ $\sim 1$  in.<sup>2</sup>] to provide adequate venting.

NOTE 3—Some dart impact machine designs utilize enclosed dart wells that do not permit adequate venting to the atmosphere during impact. Data have shown that this has a significant effect on the observed impact value, especially with films that exhibit high elongation during testing, resulting in atypically high impact values.

NOTE 4—The use of smaller, multiple vents is permitted if it can be demonstrated that the venting efficiency is comparable and has no statistically significant effect on the values obtained.

6.2.6 *Dart Holding Fixture*—An electromagnetic, pneumatic, or mechanical system to suspend the dart in position above the test specimen. It shall be adjustable vertically and horizontally relative to the impact surface to insure that the dart falls from the correct height and directly onto the center of the clamped specimen. In some equipment designs, this fixture is an integral part of the base. When the dart is in position to drop, the distance between the lower tip of the dart and the upper surface of the specimen shall be  $66 \pm 1$  cm [ $26.0 \pm 0.4$  in.]. A plumb bob shall be used to precisely center the fixture over the specimen clamp to insure that the dart strikes the center of the specimen. The fixture shall release the dart without imparting any vertical or horizontal force that might affect the trajectory of the dart.

6.2.7 *Dart*—The impact dart shall have a single  $38.10 \pm 0.13$  mm [ $1.500 \pm 0.005$  in.] diameter hemispherical stainless steel head. It shall have a mass of  $227 \pm 5$  g [ $0.50 \pm 0.01$  lb] and a shaft of sufficient length and diameter to accommodate any additional weights used to increase the mass of the dart. The shaft shall be attached to the center of the flat surface of the dart head with its longitudinal axis perpendicular to the surface. The impact surface of the dart head shall be free of nicks, scratches, or other irregularities.

NOTE 5—A stem diameter of  $9.52$  mm [ $0.37$  in.] has been found to be satisfactory to resist bending.

NOTE 6—Data have shown a sensitivity of impact results related to the condition and finish of the dart head used. The differences have been especially significant when testing films exhibiting high impact, or high elongation characteristics, or both. This issue, together with related concerns, is currently under study in Subcommittee D20.19.

6.2.8 *Dart Weights*—Weights to increase the mass of the dart in  $227 \pm 5$  g [ $0.50 \pm 0.01$  lb] increments to a total of  $1135 \pm 25$  g [ $2.50 \pm 0.05$  lb]. The diameter of the weights shall be  $31.8$  mm [ $1.25$  in.] or less and they shall attach securely to the dart stem. Weights shall be of rigid, metallic construction, that is, not filled with lead shot or other loose material. In adjusting the mass of the dart, incremental weights are added individually or as a single weight equivalent to the appropriate mass. If single weights are used, their masses shall vary in  $227$  g [ $0.5$  lb] increments.

### 6.3 Other Required Equipment: